

Note:

 parts designators refer to the
 gaussmarkov schematic

stock FTM octave switch wiring

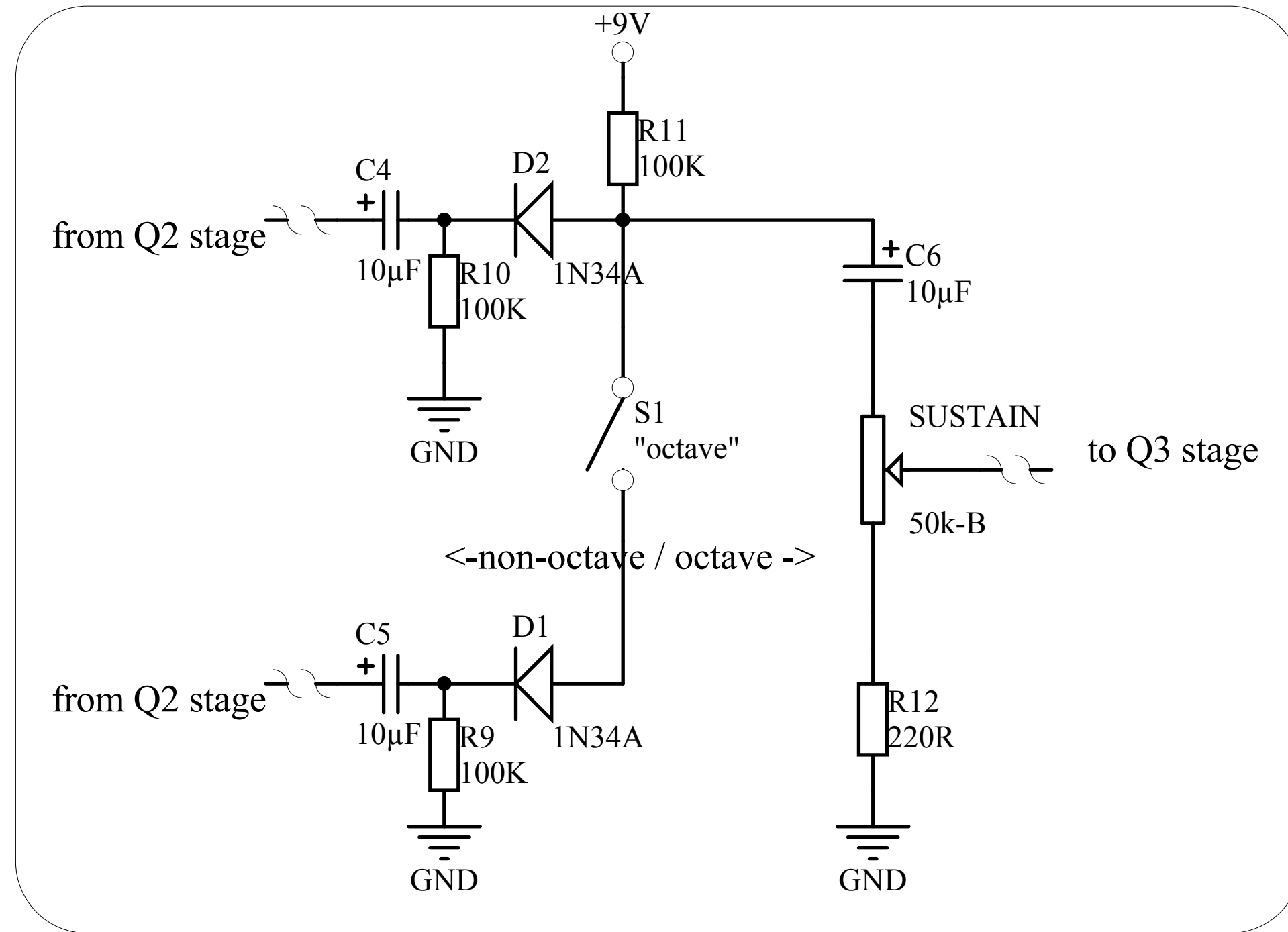

improved FTM octave switch wiring
 as suggested by Mark Hammer of diystompboxes.com

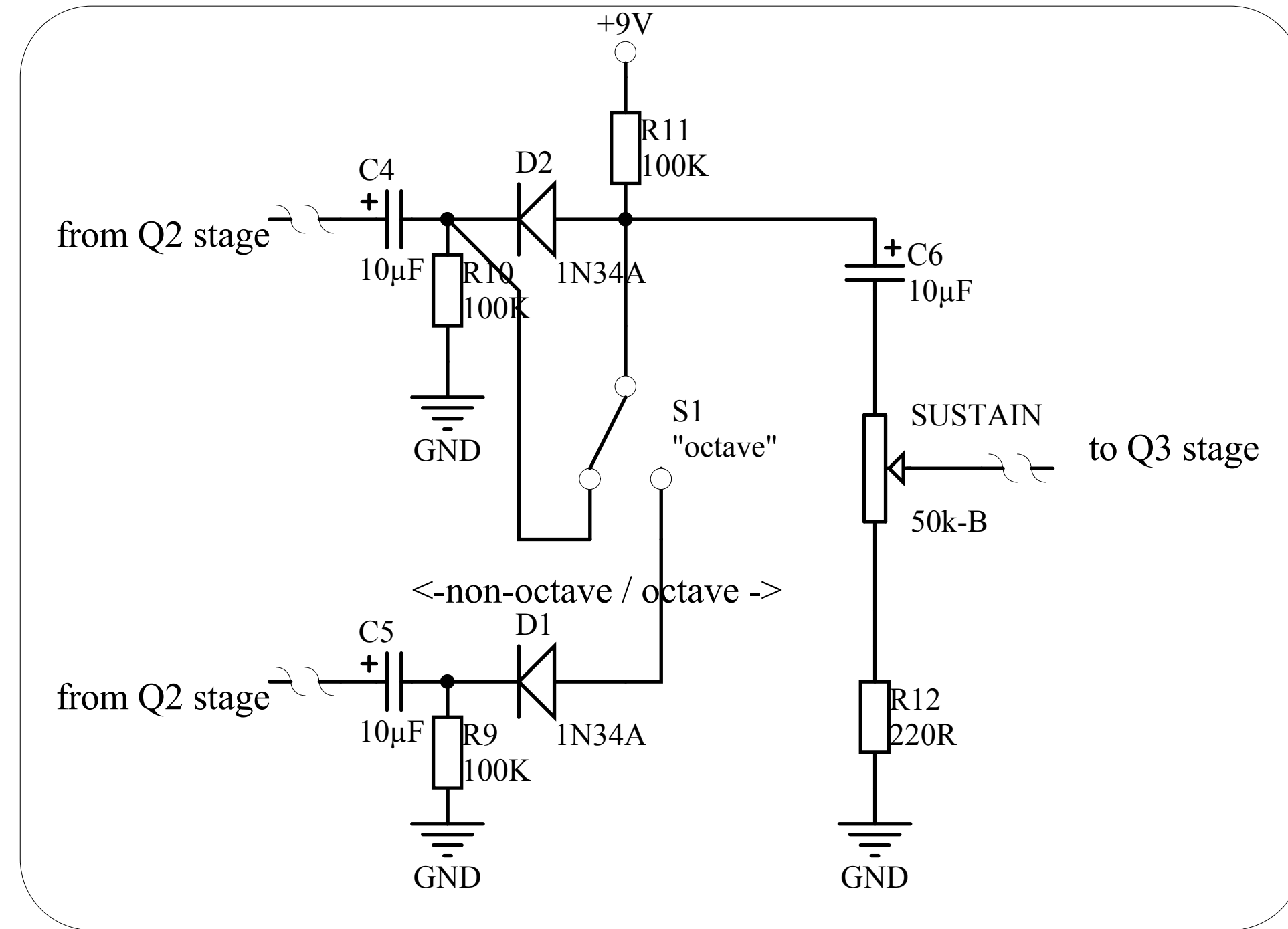

using a dpdt switch with center off position would recover the stock wiring
 in the center position

Permission refused for serving / posting
 this file from any site other than
 aquataur.at.tf

Title FOXXTONE octave switch detail		
Size A4	Number drawing (c) aquataur.at.tf	Revision 1.0
Date: 21.11.2010	Sheet of 1/1	Drawn By: H.Gragger
File: D:\projekte\...\octave switch details.SchDoc		